

Product Information

FIOIWHFL-AL-WP - Wormhole Optical Illusion with Alu Post

BS EN 1176 - Designed to British & European Standards

MATERIALS

Panels - Two Colour  High Density Polyethylene (HDPE)

Post - Extruded aluminium post with powder coat finish

SUPPLY METHOD

Disc and Cap Assembly - Pre-assembled

Post - Separate

FEATURES



ROTATE - Create an optical illusion



INCLUSIVE - Activity positioned at accessible height



DIMENSIONS

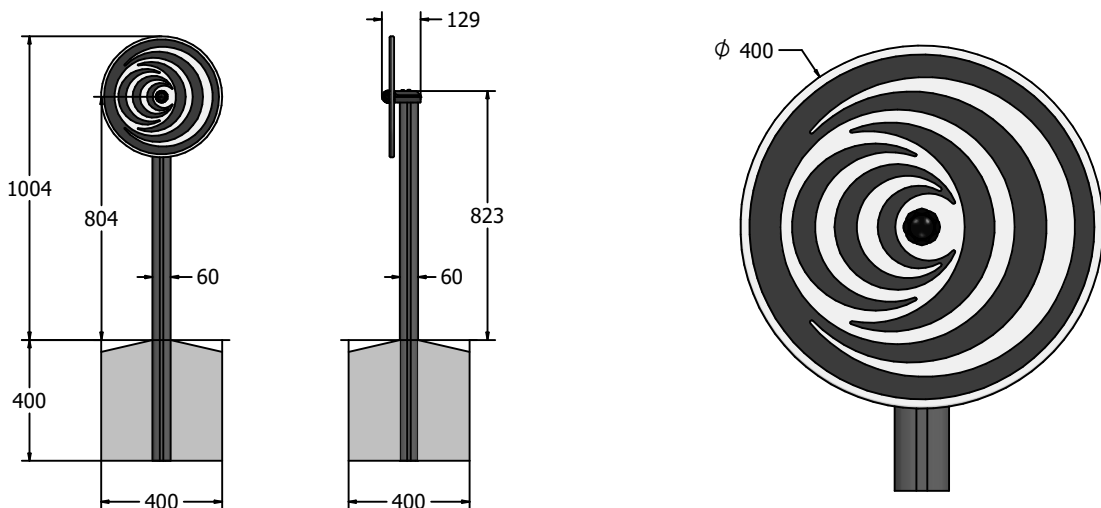

TECHNICAL

Age Range: 2+ Years
 Largest Part: Post - 60 x 60 x 1185mm
 Heaviest Part: Post - 2.2Kg
 Total Weight: 4.3Kg
 Surfacing: N/A

IMPORTANT: you must specify the colour option you require at the time of order if it is different from the colour listed/shown above, requirements are subject to availability at the time of order