

Product Information

FIFMTRACT - Terry the Tractor

BS EN 1176 - Designed to British & European Standards

MATERIALS

Panels - Two Colour High Density Polyethylene (HDPE)





Recycled Profile - Recycled plastic with textured finish

LumbeRock Benches - Recycled HDPE milk bottles with a wood grain finish

SUPPLY METHOD

Tractor - Fully assembled

FEATURES

-  **SOUNDS** - Can have tractor and farm sounds
-  **BATTERY** - Can be Battery powered
-  **ROTATE** - Spinning car wheel
-  **TUNNEL** - Ribbed Crawl Through Play Tunnel

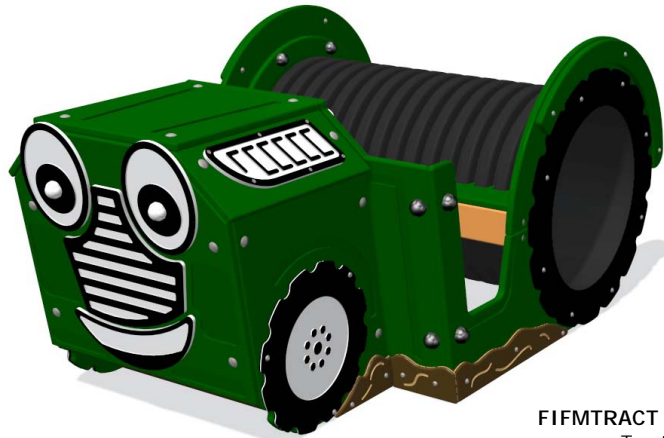

FIFMTRACT - Terry The Tractor

FIFMTRACTPT - Terry The Tractor with PlayTronic Sounds



PlayTronic
outdoor electronics

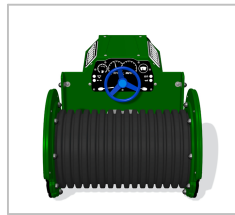

Crawl through tunnel section



Dashboard with steering wheel

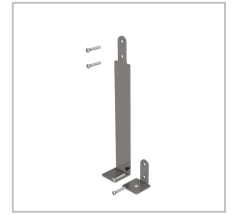

Surface or below ground fixing brackets available as an additional extra

DIMENSIONS

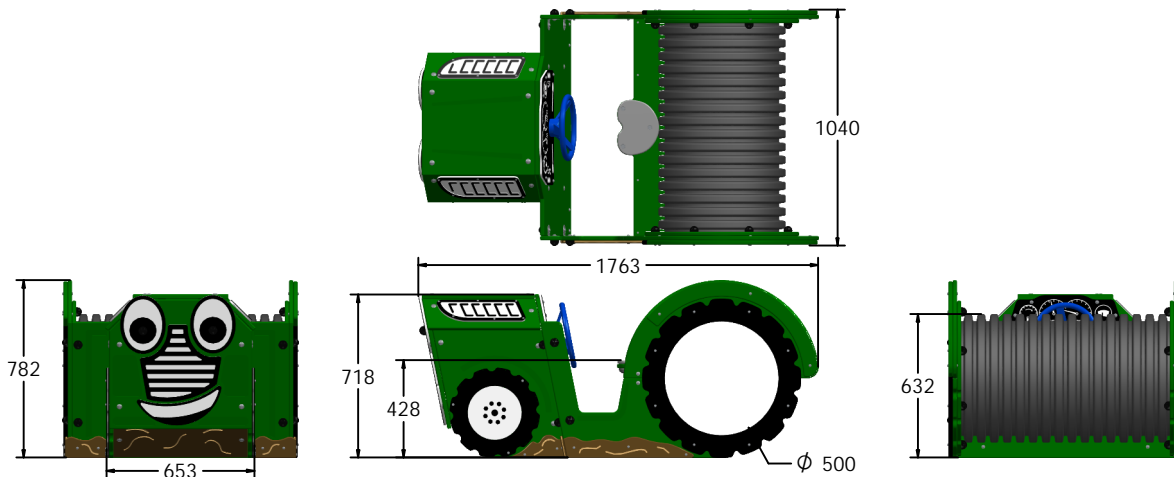

TECHNICAL

Age Range:	2+ Years
Largest Part:	Tractor Assembly - 1763 x 782 x 1040mm
Total Weight:	120kg Approx
FFH (Free Fall Height):	718mm
Surfacing:	1.5m from extents of equipment

IMPORTANT: you must specify the colour option you require at the time of order if it is different from the colour listed/shown above, requirements are subject to availability at the time of order

Product Information

FIFMTRAIL - Activity Trailer

BS EN 1176 - Designed to British & European Standards

MATERIALS

Panels - Two Colour High Density Polyethylene (HDPE)

Recycled Plastic Support - Recycled plastic with textured finish

SUPPLY METHOD

Train - Fully assembled

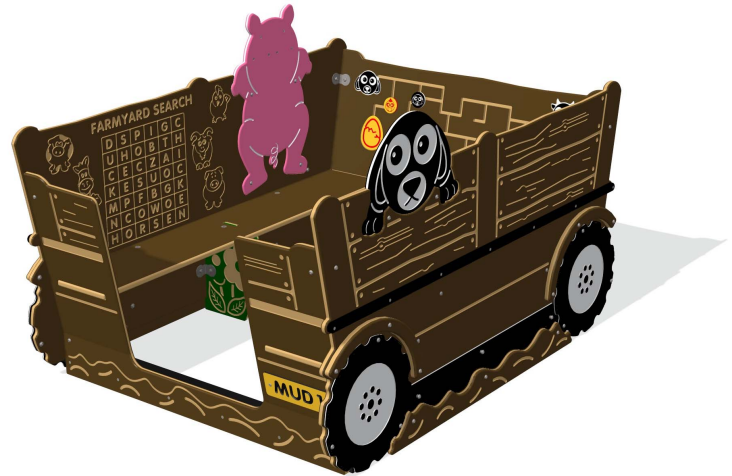

FEATURES



TOUCH - Tactile design



LETTERS - Word search puzzle



SLIDERS - Sliding counters



SOCIAL - Competitive game/activity

3 interactive games inside

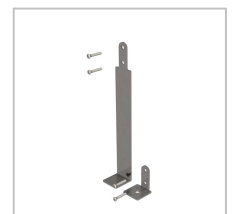
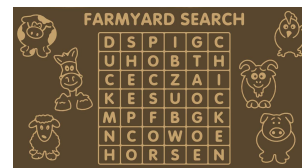
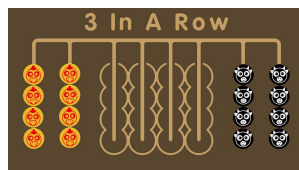

Surface or below ground fixing brackets available as an additional extra

DIMENSIONS

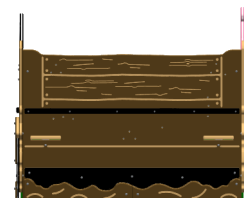
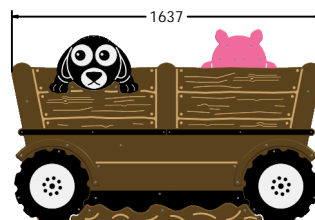
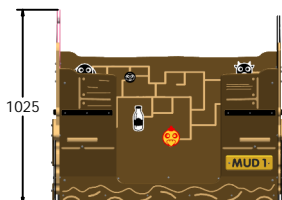

TECHNICAL

Age Range:	2+ Years
Largest Part:	Trailer Assembly - 1637 x 1025 x 1241 mm
Total Weight:	108kg Approx
FFH (Free Fall Height):	350mm
Surfacing:	N/A

IMPORTANT: you must specify the colour option you require at the time of order if it is different from the colour listed/shown above, requirements are subject to availability at the time of order