

Product Information

FSSR2-B - 2-Way Spring Rocker

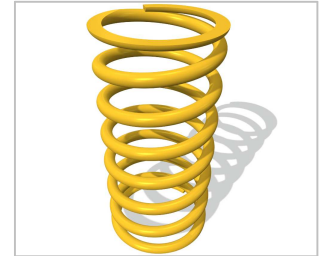

Heavy Duty Steel Spring

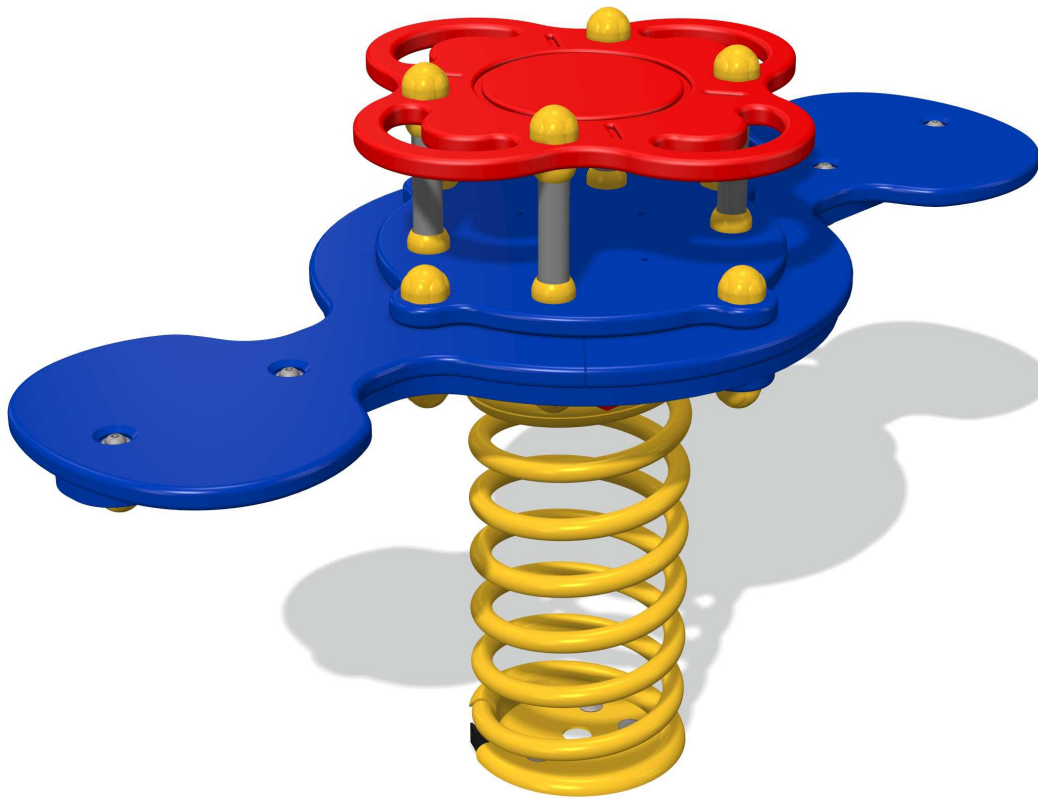

Steel Reinforced Seat

Designed to British & European
Standard BS EN 1176

Supply Method
Spring Rocker Seat section
pre-assembled to assist
easy installation.

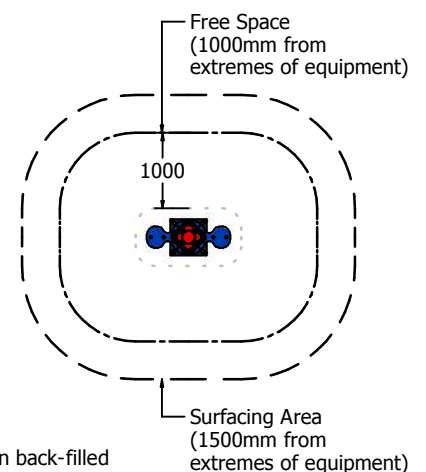
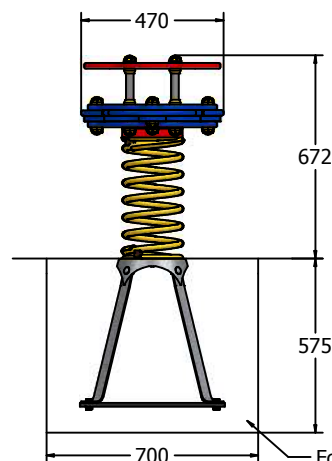
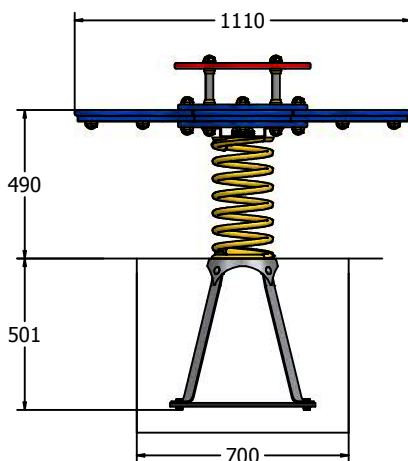

Age Range: 3 to 7
Largest Part: Spring Rocker Seat Assembly 1110 x 470 x 125mm
Total Weight: 42kg approx.
Heaviest Part: Seat Assembly - 18kg approx.
Free Height of Fall (FFH): 672mm
Surfacing : 1.5m from the extremes of the equipment with a Critical Fall Height in excess of 672mm

Material: **Design Panel** - High Density Polyethylene (HDPE) with orange peel texture finish
Spring & Brackets - Powder coated steel
Ground Anchor - Galvanised steel

Colour Choices: **Design Panel** - Broad selection available, visit the website below for further details